

# S676-400U-01

325 to 1200 Watt Alternator

---

## Featuring:

- 3 Phase brushless design
  - Designed for direct drive on engine crankshaft
  - Only one moving part, an optional sealed ball bearing, which can be eliminated when rigidly mounted
  - NdFeB magnets
  - Humidity and moisture-resistant
- 



# S676-400U-01

325 to 1200 Watt Alternator

## Specifications

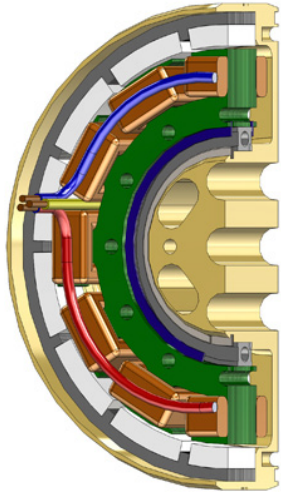

<b>Model number:</b>	<b>S676-400U-01</b>
Alternator diameter:	102mm
Alternator thickness:	26mm
Alternator weight:	670g
Engines:	Most engines 20cc to 80cc
Rated power at 2500 RPM:	325W
Rated power at 7500 RPM:	1200W
Standard wind type:	Three phase
No-load voltage constant:	11.0 VAC/1000 RPM (rms voltage, line to line)
Thermal: (Rotor)	Continuous Operation* 85°C Absolute Maximum* 120°C *Higher temperature available but maximum power will be reduced
Thermal: (Stator)	Continuous Operation 120°C Absolute Maximum 200°C
Options:	Special winding Modified shell machining

# S676-400U-01

325 to 1200 Watt Alternator



## Performance

**Rated Power vs RPM**  
**S676-400U-01**  
(120 Max °C Stator Temperature)

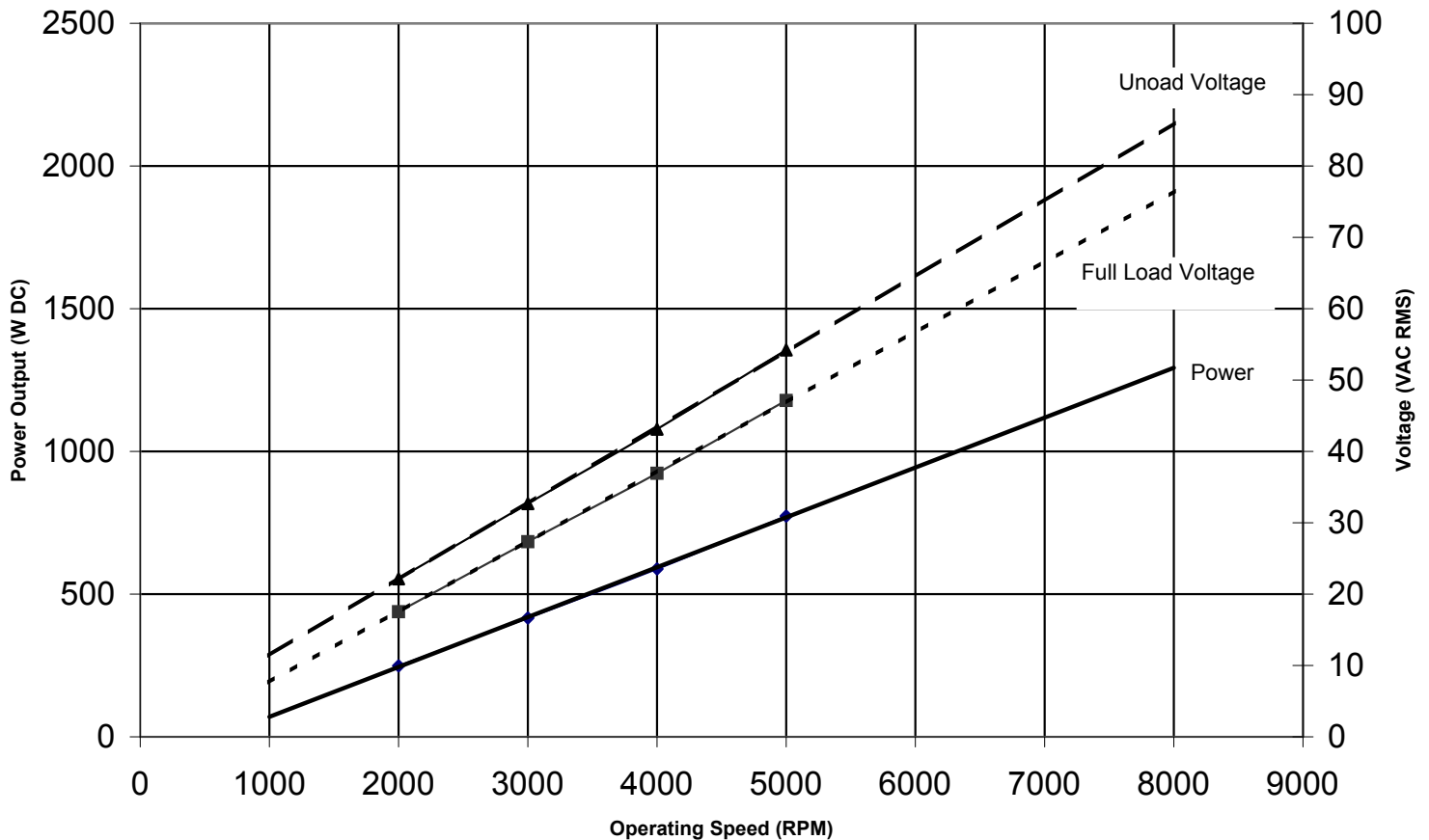

### Sullivan UV

8950 Yellow Brick Rd

Baltimore, MD 21237

Phone: 410-732-3500 Fax: 410-327-7443

W: [www.SullivanUV.com](http://www.SullivanUV.com) E: [sales@sullivanuv.com](mailto:sales@sullivanuv.com)

Sullivan UV is a Baltimore, Maryland-based manufacturer of custom crafted starters, alternators and control hardware.

# S676-400U-01

325 to 1200 Watt Alternator



## Mounting

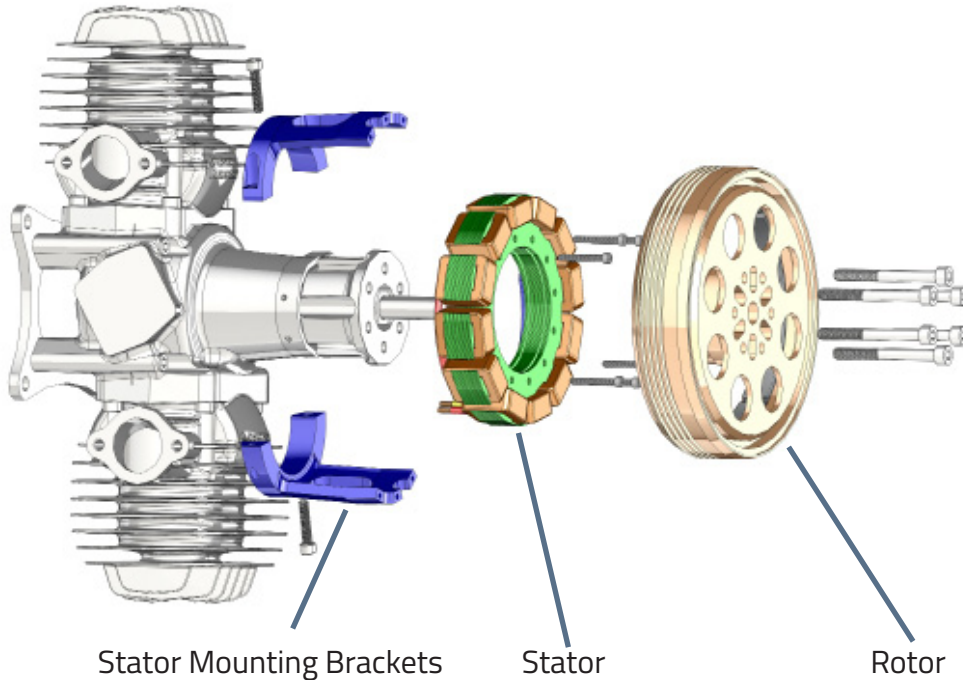

3W-28i with S676-300F-01

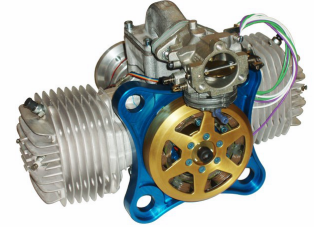

3W-342 with rear mounted  
S676-500



3W-200 with S675-500

Sullivan Pancake Alternators are typically designed to be directly driven by the engine crankshaft. They consist of three main parts, Rotor, Stator, and the Stator Support Bracket. The Rotor and Stator are common for most installations, while the Stator Support Brackets are specific to each engine and alternator combination.

The **Rotor** is affixed directly to the crankshaft and is supported by the crankshaft bearings. Placement can be on the front shaft between the Propeller Hub and Propeller, or on the rear shaft when available. Other installation configurations can also be accommodated.

The **Stator** is mounted to the engine crankcase via the Stator Mounting Bracket. The Stator is held rigidly in place concentric to the Rotor, with the windings and magnets aligned axially. An optional thin section bearing can be included that provides the proper alignment between the Rotor and Stator if needed.

The **Stator Mounting Brackets** are typically CNC machined from Billet Aluminum. They attach to the engine by either clamping to existing features or bolting directly to the crankcase. In some cases it is necessary to drill and tap the crankcase to create mounting points. The Stator is then bolted to the Mounting Bracket to complete the installation. Installation guides can be downloaded at [www.SullivanUV.com](http://www.SullivanUV.com)

For advanced systems, stator mounting features can be incorporated into the crankcase design which eliminate the need for the bearing and brackets. This approach saves considerable weight and cost but requires control over the engine manufacturing process. If this option is available please contact Sullivan Sales and Engineering, [Sales@SullivanUV.com](mailto:Sales@SullivanUV.com), to discuss the details.

# Efficiency

Efficiency v. Output  
S676-400U-01

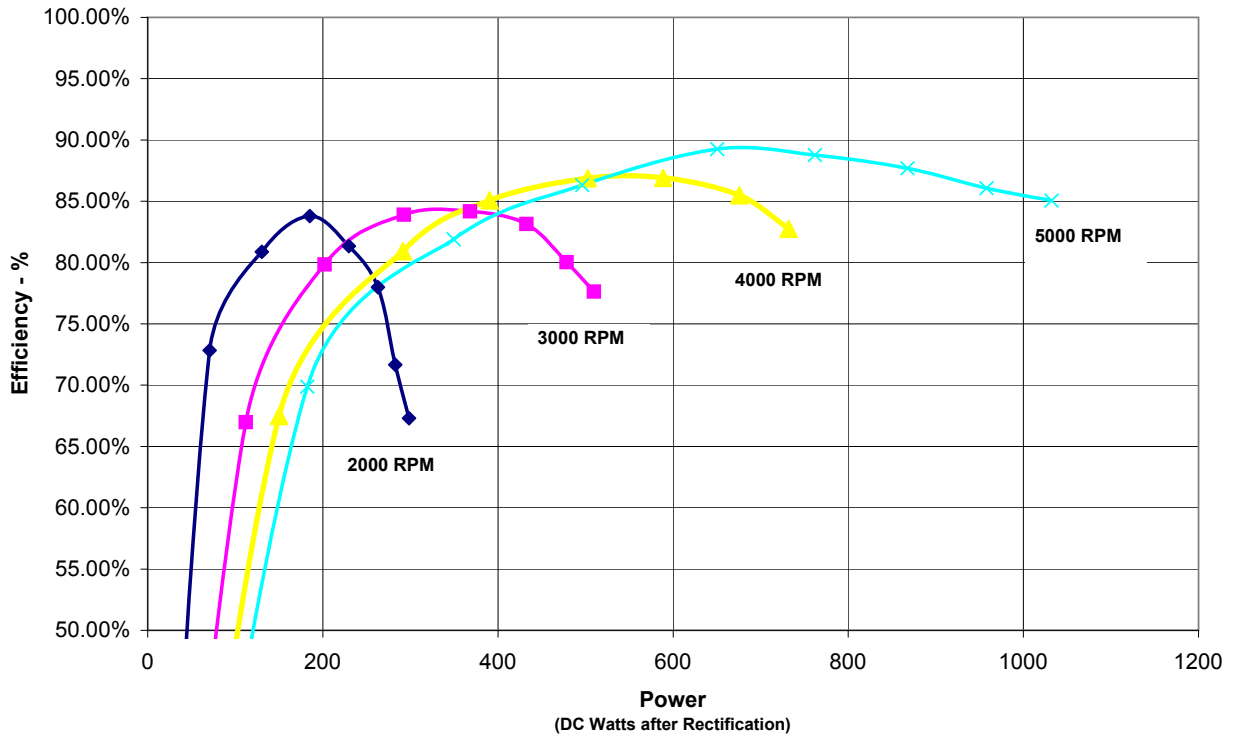

## Engine load calculations

$$\text{Engine load} = \text{Output power} / \text{Regulator Efficiency} / \text{Alternator Efficiency}$$

Example: A 225W electrical load at 90% regulator efficiency and 80% alternator efficiency requires  $225 / 0.90 / 0.80 = 312.5\text{W}$  of engine power. At 746W/HP, this is 0.419 HP.

$$\text{Ft-Lbs of Torque} = \text{Horsepower} * 5252 / \text{RPM}$$

At 3800 RPM, a 225W load with a 90% efficient regulator and 80% efficient alternator, the torque load would be  $0.419\text{HP} * 5252 / 3800 = 0.579 \text{ Ft-Lbs}$ .

$$1 \text{ Ft-Lb} = 1.356 \text{ N-M}$$

0.579 Ft-Lbs of torque is 0.785 N-M.

# S676-400U-01

325 to 1200 Watt Alternator

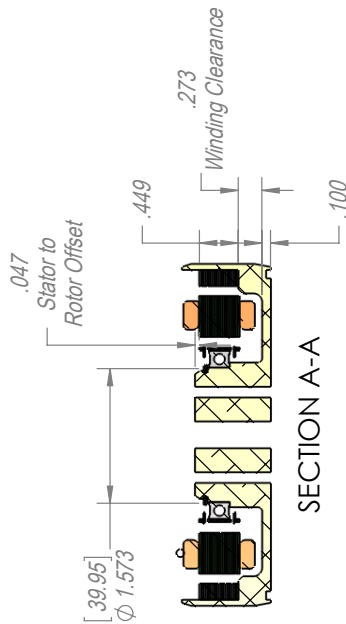
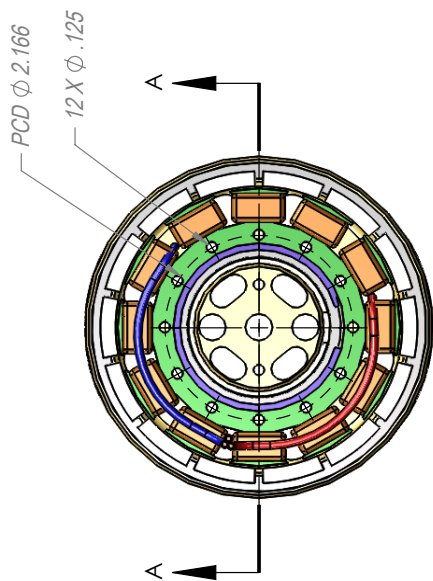
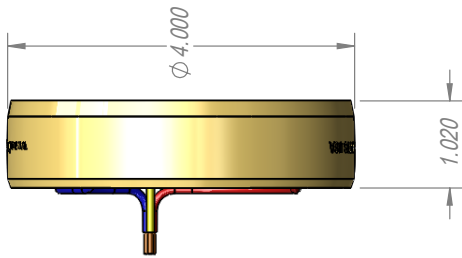
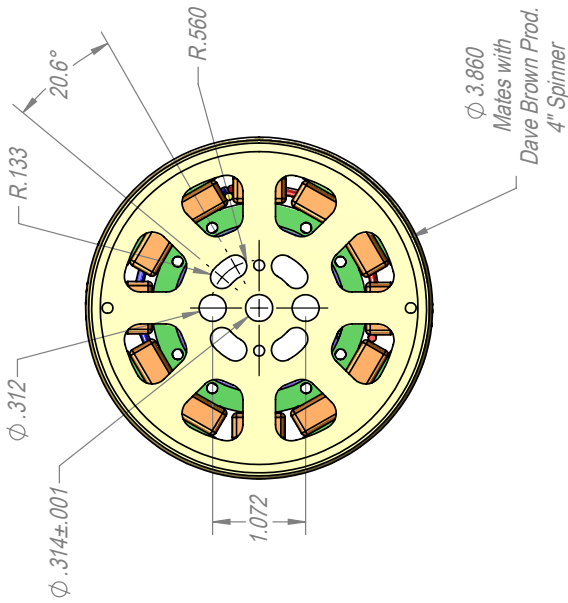

Typical Built Weight\*: 670 grams  
 Rotor: 320 grams  
 Stator: 325 grams  
 \*includes bearing, retaining rings, and lead wires

UNLESS OTHERWISE SPECIFIED:		NAME	DATE
DIMENSIONS ARE IN INCHES		KP	12/12/2014
TOLERANCES:			
FRACTIONAL: 1/64			
ANGULAR: MACH: BEND ±			
TWO PLACE DECIMAL ± .010			
THREE PLACE DECIMAL ± .005			
INTERPRET GEOMETRIC TOLERANCING PER:			
MATERIAL:			
FINISH:			
DO NOT SCALE DRAWING			
		PROPRIETARY AND CONFIDENTIAL	
		THE INFORMATION CONTAINED IN THIS DRAWING IS THE SOLE PROPERTY OF THE PERFECT PARTS COMPANY. ANY REPRODUCTION IN PART OR AS A WHOLE WITHOUT THE WRITTEN PERMISSION OF THE PERFECT PARTS COMPANY IS PROHIBITED.	

Sullivan UV		REV
TITLE:		N/C
S676-400U-01 Assembly		
SIZE	DWG. NO.	REV
A	S676-400U-01 ICD	N/C
SCALE: 1:2	WEIGHT:	SHEET 1 OF 1

