



SREGS-350U-01

350 Watt Power Management Unit

Typical Applications:

- Remote Power Generation
- Power Regulation from Alternative sources, ex. wind or solar
- Unmanned Air Vehicles (UAV's) and Unmanned Ground Vehicles (UGV's)

Featuring:

- 3 Phase AC primary input, 25 - 95 VACrms.
- Configurable to support LiPo, Lilon, LifePO4, NiCad, NiMH, SLA, and Lead Acid Battery Backup.
- Two simultaneous output voltages, 20 - 30 VDC 13 Amps and 4.8 - 8 VDC 7 Amps
- MIL-SPEC circular connectors
- Operates up to 91% efficiency at peak power.
- Provides automatic switching for DC ground power, and back up battery sources



SREGS-350U-01

350 Watt Power Management Unit



Specifications



Output:	Conditions	Min	Max	Input:	Conditions	Min	Max
Main Output:	13A/350W Max	20 VDC*	30 VDC*	Alternator Input Voltage:	3Ø 0 - 1 KHz	25 VAC	95 VAC
Secondary Output:	7A/42W Max	4.8 VDC*	8 VDC*	Backup Battery:	LiPO, Lilon, LifePO4, NiCad, NiMH, SLA, Lead Acid*	24 VDC	32 VDC
Maximum Total Power:			350 Watts	External Shore Power:	DC	24 VDC	32 VDC
Peak Efficiency:			91%	Battery Switch Time:	No interruption of Output		250nS
Self Protection:	Overvoltage, Undervoltage, Overcurrent, Reverse EMF			Mechanical: Conditions			
Maximum Overload Current:	Up to 10mS duration		125%	Enclosure Material:	Black Anodized Aluminum		
Output Ripple, Maximum:	p-p All Outputs		500mV	Dimensions:	48 mm x 64 mm x 139 mm		
Voltage Regulation:	All outputs		+/-500mV	Weight:	350g		
Status Signal:	5V High Impedance			Connectors:	MIL-SPEC Circular Connectors		
Battery Charger Type:	Basic, Cell monitoring, or Full balance charging options available			Design Standard:	MIL-STD 1275D		
Back-up Battery Charging:	LiPO, Lilon, LifePO4, NiCad, NiMH, SLA, Lead Acid*		900mA	Conformal Coating:	MIL-I-46058C Type UR		
				Cooling:	11 CFM Fan, may be replaced by forced air		
				Operating Temperature:	-20C to 55C Ambient		
				Storage Temperature:	-40C to 85C		

*Factory Adjustable

SREGS-350U-01

350 Watt Power Management Unit



SULLIVAN UV SREGS-350U-01 PMU Block Diagram

Created: Jan. 19, 2015
Revised: N/A

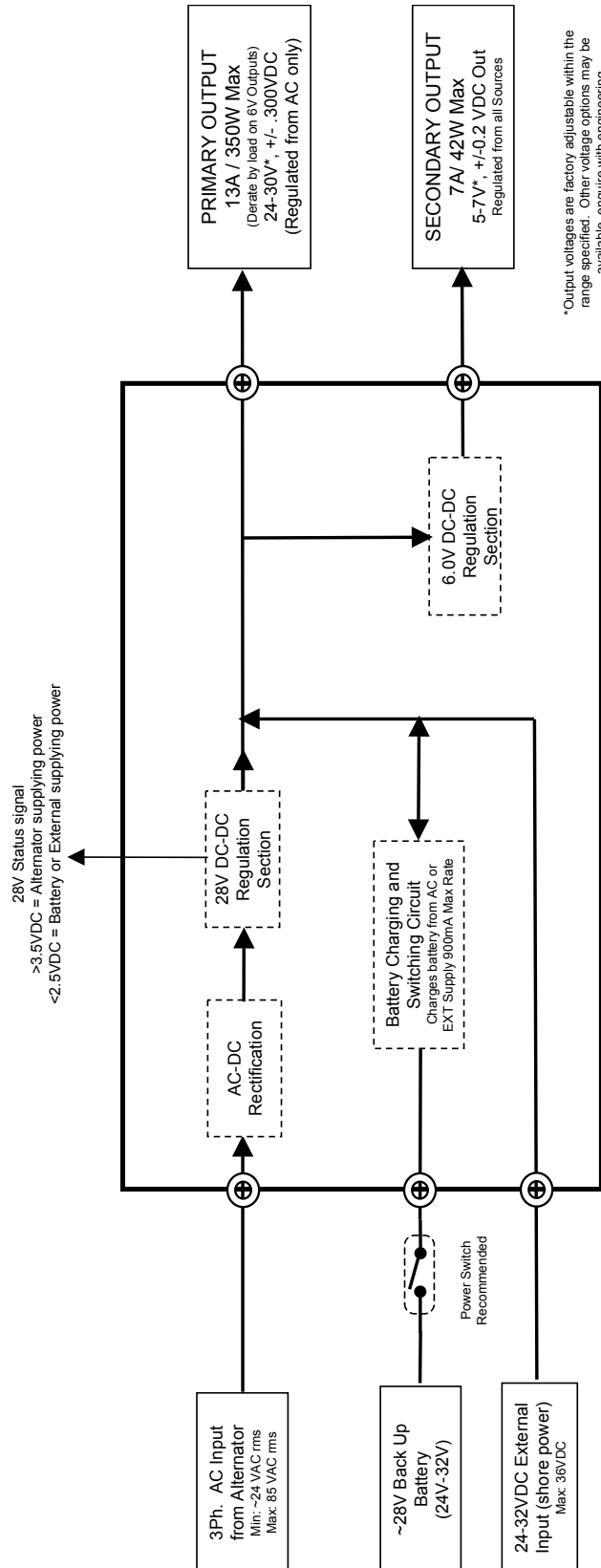

*Output voltages are factory adjustable within the range specified. Other voltage options may be available, enquire with engineering

General Notes:

- Customer responsible for fusing all loads
- Battery recharges from External Input or AC input
- Enclosure type: 1CN SREGS V1
- All connections are MIL-5051 Circular Connectors
- All outputs are filtered to 100Mhz to 1 Ghz and include protection against Reverse Polarity Transients, Etc

Performance

Allowable Storage and Operating Temperature Profile

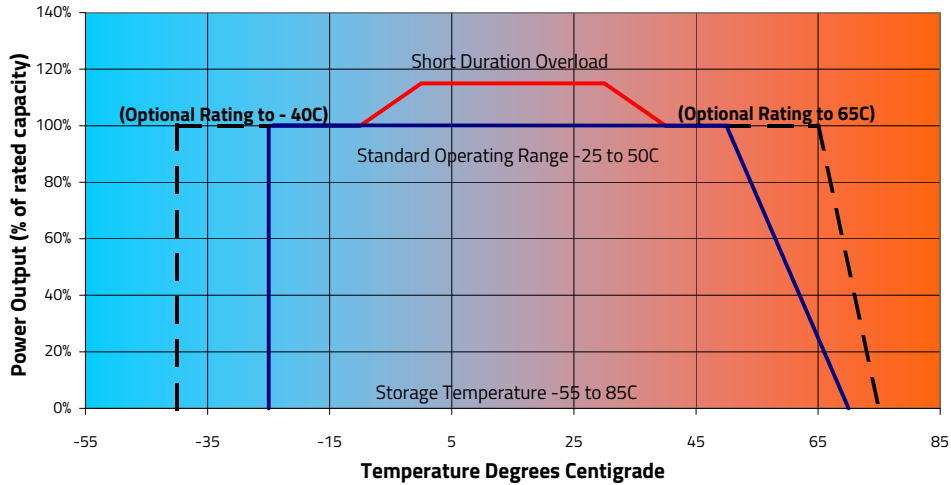

Power Derating due to Altitude

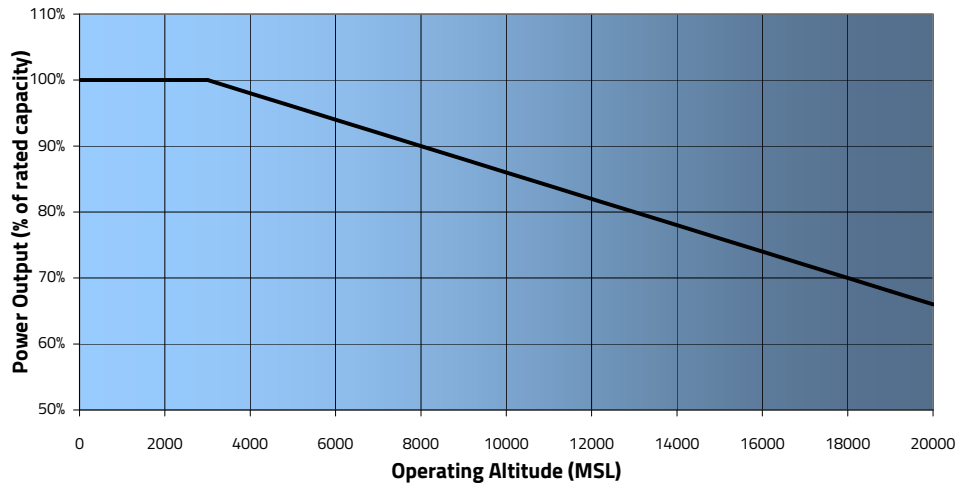

Alternator Input Range

28V Primary Output

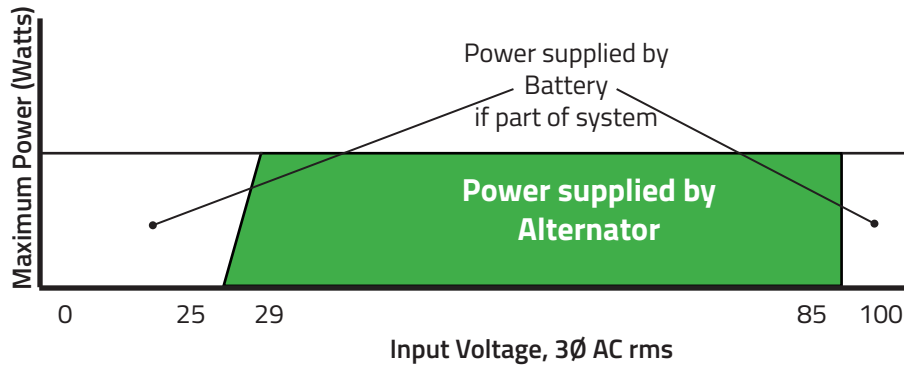

Efficiency

Typical PMU Efficiency vs Output Current

Input: 65 VDC

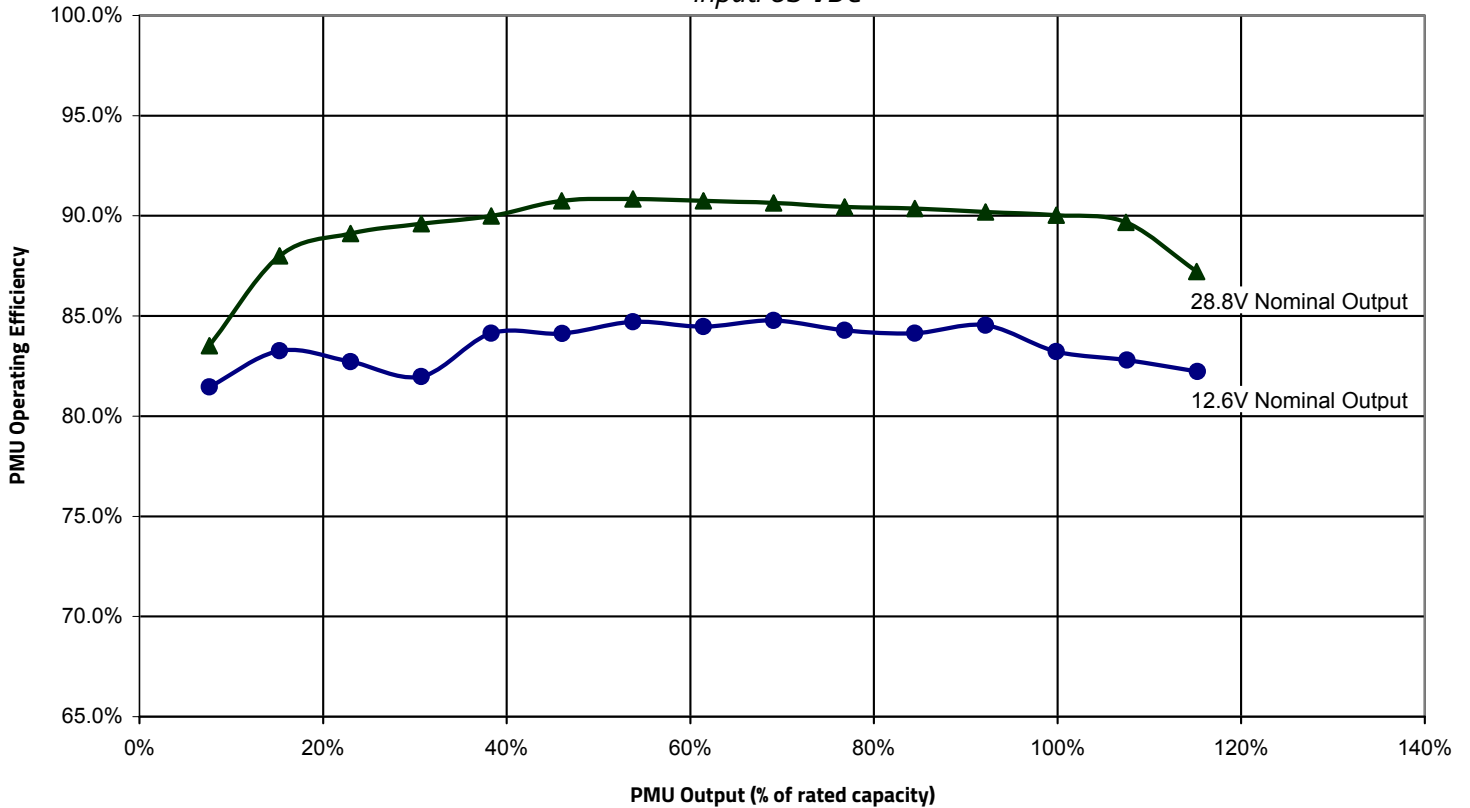

Engine load calculations

$$\text{Engine load} = \text{Output power} / \text{Regulator Efficiency} / \text{Alternator Efficiency}$$

Example: A 225W electrical load at 90% regulator efficiency and 80% alternator efficiency requires $225 / 0.90 / 0.80 = 312.5\text{W}$ of engine power. At 746W/HP, this is 0.419 HP.

$$\text{Ft-Lbs of Torque} = \text{Horsepower} * 5252 / \text{RPM}$$

At 3800 RPM, a 225W load with a 90% efficient regulator and 80% efficient alternator, the torque load would be $0.419\text{HP} * 5252 / 3800 = 0.579 \text{ Ft-Lbs}$.

$$1 \text{ Ft-Lb} = 1.356 \text{ N-M}$$

0.579 Ft-Lbs of torque is 0.785 N-M.

SREGS-350U-01

350 Watt Power Management Unit

Typical Weight: 350 grams
 Enclosure: 133g
 Connectors: 54g (26, 28)
 Fan: 28g
 Internal Components: 132g

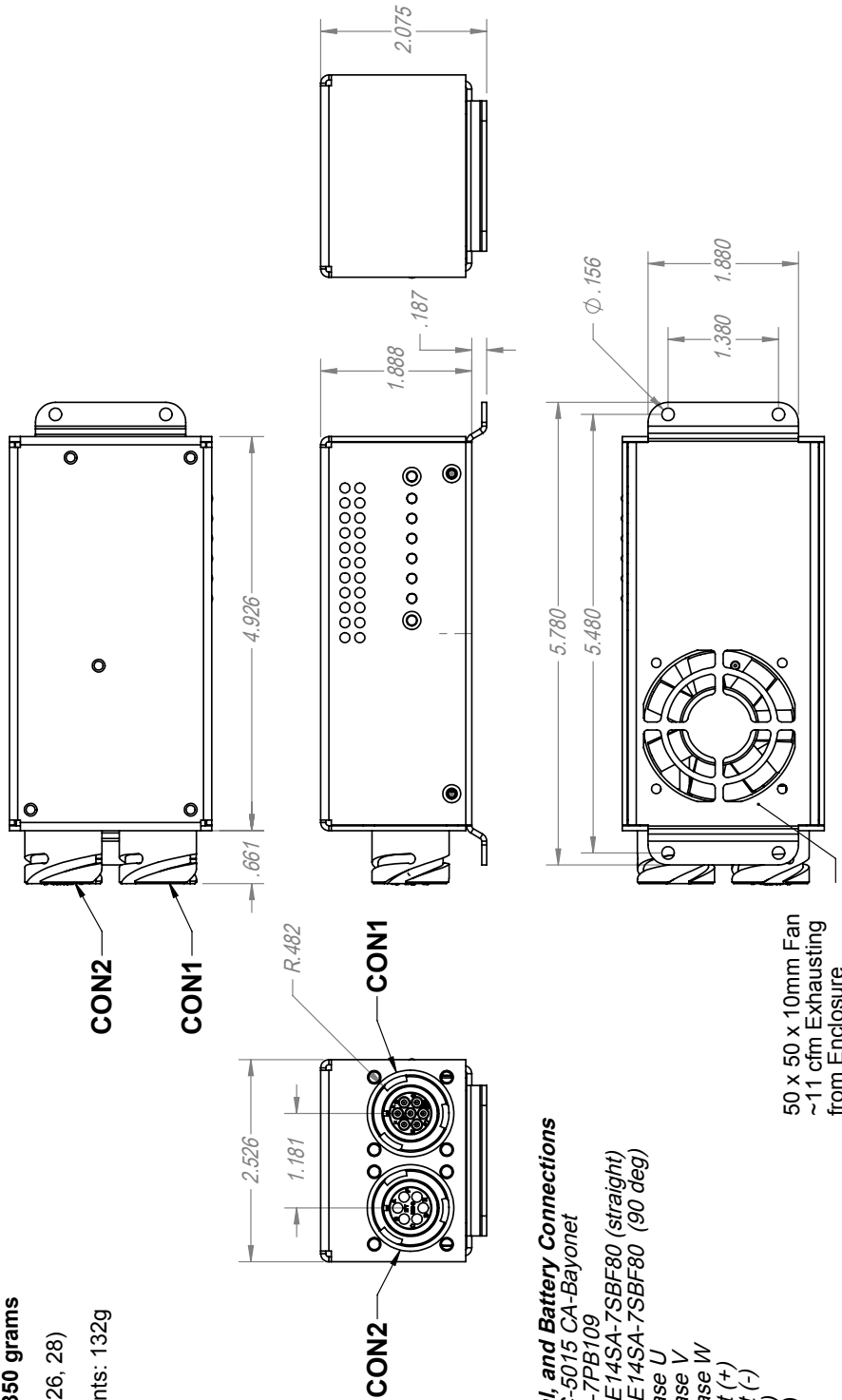

CON1: AC, External, and Battery Connections

ITT CANNON MIL-C-5015 CA-Bayonet
 P/N: CA3102E14SA-7PB109
 Mates with: CA3106E14SA-7SBF80 (straight)
 CA3108E14SA-7SBF80 (90 deg)
 Pin A: AC Input, Phase U
 Pin B: AC Input, Phase V
 Pin C: AC Input, Phase W
 Pin D: External Input (+)
 Pin E: External Input (-)
 Pin F: Battery I/O (+)
 Pin G: Battery I/O (-)
 16G wires for all

CON2: Primary output, Secondary output, Status

ITT CANNON MIL-C-5015 CA-Bayonet
 P/N: CA3102E14S-6SB109
 Mates with: CA3106E14S-6PBF80 (straight)
 CA3108E14S-6PBF80 (90 deg)
 Pin A: Primary Output (+)
 Pin B: Primary Output (-)
 Pin C: Secondary Output (+)
 Pin D: Secondary Output (-)
 Pin E: Alternator Status (+)
 Pin F: Alternator Status (-)
 16G wires for outputs, 20-24G for Status

UNLESS OTHERWISE SPECIFIED:		NAME	DATE	Sullivan UV	
DIMENSIONS ARE IN INCHES		KP	11/18/2013	TITLE:	
FRACTIONAL: 1/64				1CN SREGS V1 Assembly	
ANGULAR: MACH ±	BEND ±			SIZE	DWG. NO.
TWO PLACE DECIMAL ± .010	THREE PLACE DECIMAL ± .005			A	REV
INTERPRET GEOMETRIC TOLERANCING PER:		Q.A.		SCALE: 1:2	WEIGHT:
MATERIAL		PROPRIETARY AND CONFIDENTIAL			SHEET 1 OF 1
FINISH		THE INFORMATION CONTAINED IN THIS DRAWING IS THE SOLE PROPERTY OF THE PERFECT PARTS COMPANY. ANY REPRODUCTION IN PART OR AS A WHOLE WITHOUT THE WRITTEN PERMISSION OF THE PERFECT PARTS COMPANY IS PROHIBITED.			
DO NOT SCALE DRAWING					